

# **Rechargeable Li-ion Battery FB-L-5.12 Operation Manual**

Information Version: 1.2  
5PMPA08-20019



# Legal Information

**Copyright©2025 Pylon Technologies Co., Ltd. All rights reserved.**

Any reproduction or distribution of this manual or any part of this manual, or any uploading of this manual to a third party website, in any form by any means, without the prior written consent of Pylon Technologies Co., Ltd., is prohibited.

## **Disclaimer**

The manual contains instructions for the use of the product. All the pictures and charts in this manual are for description and explanation only. Pylon Technologies Co., Ltd. reserves the right to change the information in the manual which is subject to change without further notice.

Please read this manual carefully before using the product and keep this manual for further reference. Failure to use the product in accordance with the manual may result in serious injuries, property damages and may void the warranty, for which Pylon Technologies Co., Ltd. shall not be liable.

Pylon Technologies Co., Ltd. makes no representations or warranties express or implied, with respect to all the information in this manual.

In the event of any conflicts between this manual and the applicable law, the latter prevails.

The final interpretation of this manual belongs to Pylon Technologies Co., Ltd.

# Contents

<b>1</b>	<b>Information about this manual .....</b>	<b>6</b>
1.1	Purpose.....	6
1.2	Explanation of Symbols .....	6
<b>2</b>	<b>Safety.....</b>	<b>7</b>
2.1	Symbols.....	7
2.2	Personal Requirements .....	8
2.3	General Safety .....	8
2.4	Safety Instructions Before Connecting the Battery.....	10
<b>2.5</b>	<b>Safety Instructions in Using the Battery .....</b>	<b>10</b>
<b>3</b>	<b>System Introduction .....</b>	<b>11</b>
3.1	Features.....	11
3.2	Specifications .....	12
3.3	Battery Interface.....	13
<b>4</b>	<b>Safe Handling of Lithium Batteries.....</b>	<b>18</b>
4.1	Schematic diagram of solution.....	18
4.2	Labels .....	18
<b>5</b>	<b>Installation.....</b>	<b>19</b>
5.1	Checking Before the Installation.....	19
5.2	Preparing Tools and Instruments.....	19
5.3	Selecting the Installation Sites .....	20
5.4	Installation Direction.....	21
5.5	Installing the Batteries.....	23
5.5.1	Mounting the Battery on the Wall .....	23
5.5.2	Installing the Battery into the Cabinet or Rack.....	25
5.5.3	Installing the Batteries by Simple Brackets.....	26
<b>6</b>	<b>Cable Connection.....</b>	<b>27</b>
6.1	Checking Cables.....	27
6.2	Connecting the Grounding Cable.....	27
6.3	Single-string Cable Connection .....	28





6.4	Multi-string Cable Connection .....	30
6.5	Suitable disconnection device.....	31
<b>7</b>	<b>Commissioning.....</b>	<b>32</b>
7.1	System Turning On.....	32
7.2	System Turning Off.....	32
<b>8</b>	<b>Trouble shooting .....</b>	<b>33</b>
<b>9</b>	<b>Emergency Situations.....</b>	<b>36</b>
<b>10</b>	<b>Remarks .....</b>	<b>37</b>
10.1	Recycle and disposal.....	37
10.2	Storage, Maintenance and Expansion .....	37

# 1 Information about this manual

## 1.1 Purpose











This manual describes the Pylontech Fidus battery FB-L-5.12 (Unless otherwise stated, all the FB-L-5.12 information applies to the FB-L-5.12-B) in terms of its overview, installation, commissioning, etc. Please read this manual before installing the battery and follow the instructions carefully during installation. In case of any confusion, please contact Pylontech immediately for advice and clarification (Contact information can be found on the back cover of the manual).

## 1.2 Explanation of Symbols

Symbol	Description
	<b>Danger:</b> Indicates a hazard with a high level of risk which, if not avoided, will result in death or serious injury.
	<b>Warning:</b> Indicates a hazard with a medium level of risk which, if not avoided, could result in death or serious injury.
	<b>Caution:</b> Indicates a hazard with a low level of risk which, if not avoided, could result in minor or moderate injury.
	<b>Notice:</b> Indicates a potentially hazardous situation which, if not avoided, could result in equipment damage, data loss, performance deterioration, or unanticipated results.  NOTICE is used to address practices not related to personal injury.

## 2 Safety

### 2.1 Symbols

Icon	Meaning	Icon	Meaning
	Read the manual before installing and operating the product.		Do not connect the positive and negative reversely.
	General warning label indicating potential hazards.		Keep away from flame or ignition sources.
	Warning: electric shock.		Keep away from children.
	Warning: flammable materials.		Label for Waste Electrical and Electronic Equipment (WEEE) Directive (2012/19/EU).
	Warning: Do not touch the enclosure of the operating product.		The system meets the requirements of the applicable EU directives.
	The IEC certificate label for Safety by TÜV Rheinland.		

## 2.2 Personal Requirements

Qualified personnel must have the following skills:

- Training in the installation and commissioning of the electrical system, as well as the dealing with hazards.
- Knowledge of the manual and other related documents.
- Knowledge of the local regulations and directives.

## 2.3 General Safety

### Declaration

This system is only operated by authorized personnel. Read all safety instructions carefully prior to any work and follow these instructions at all times when working with the system.

Incorrect operation or work may cause:

- Injury or death to the operator or a third party.
- Damage to the system hardware and other properties belonging to the operator or a third party.

### General Requirements

#### DANGER

**Danger:** Batteries deliver electric power, resulting in burns or a fire hazard when short circuit or incorrect installment occurs.

#### DANGER

**Danger:** Lethal voltages are present in the battery terminals and cables. Severe injuries or death may occur if you touch the cables and terminals.

#### WARNING

**Warning:** DO NOT open or deform the battery module, otherwise the product will be out of warranty scope.

#### WARNING

**Warning:** Whenever operating the battery system, wear suitable personal protective equipment (PPE) such as rubber gloves, rubber boots and goggles.

 **WARNING**

**Warning:** For battery installation, the installer shall refer to NFPA70 or similar local installation standard for operation.

 **WARNING**

**Warning:** Pulling out the connectors while the system is working could lead to battery system damage or personal injury. Do not pull out the connectors while system is in operation.

 **CAUTION**

**Caution:** Improper settings or maintenance can permanently damage the battery.

 **CAUTION**

**Caution:** Battery needs to be recharged within 12 hours, after fully discharged.

 **CAUTION**

**Caution:** Risk of electric shock, do not remove cover. There is no user serviceable parts inside, refer servicing to qualified and accredited service technicians

 **WARNING**

**Warning:** Operations below must be accomplished by licensed technician or Pylontech authorized person.

## 2.4 Safety Instructions Before Connecting the Battery

### CAUTION

#### Caution:

- After unpacking, please check product and packing list first, if the product is damaged or lack of parts, please contact the local retailer.
- Before installation, ensure to cut off the grid power and ensure that the battery is in the switched-off mode.
- Wiring must be correct, do not mistake the positive and negative cables, and ensure no short circuit with the external device.
- DO NOT connect the battery with AC power directly.
- The embedded BMS in the battery is designed for **51.2 VDC**. DO NOT connect battery in series.
- Battery system must be well grounded and the resistance must be less than 100 mΩ.
- Please ensure the electrical parameters of battery system are compatible to related equipment.
- Keep the battery away from water and fire.

## 2.5 Safety Instructions in Using the Battery

### CAUTION

#### Caution:

- If the battery is stored for long time, it is required to be recharged every six months, and the SOC should not be less than 90%.
- Battery needs to be recharged within 12 hours after being fully discharged.
- If the battery system needs to be moved or repaired, the power must be cut off and the battery is completely shut down in advance.
- DO NOT connect the battery with other different type of battery.
- DO NOT let the batteries work with faulty or incompatible inverter.
- DO NOT disassemble the battery (QC tab removed or damaged).
- In case of fire, only dry powder fire extinguisher can be used. DO NOT use liquid fire extinguishers.
- DO NOT open, repair or disassemble the battery unless by staff from Pylontech or authorized by Pylontech. We do not undertake any consequences or related responsibility due to violation of safety operation or violation of design, production and equipment safety standards.

## 3 System Introduction

### 3.1 Features

Pylontech Fidus is a new product series developed by Pylontech in 2025 for residential energy storage, which includes Pylontech's own Fidus Inverter and Fidus battery.

The following are the features of Fidus battery.

- Strong environmental adaptability with IP65 protection design, applied in outdoor or high humidity scenarios,
- Wall mounting design, compatible with plug-in box and self-stacking, achieving a variety of installation methods.
- Enabling 97% depth of discharge, available for the inverter which completely follows Pylontech latest protocol.
- Up to 20 batteries in parallel can be supported in single string, up to 6 strings of batteries can be expanded to parallel use.
- External Wi-Fi stick can be hung to realize the whole group of battery information networking to the cloud, using Pylontech APP or Pylontech cloud to view the battery data.
- FB-L-5.12 uses 250 A power terminals, and a single battery can be connected to up to two pairs of power cables. The two pairs of power cables can support 400 A continuous current. (FB-L-5.12-B uses 125 A power terminals).
- Supporting 1 C continuous, 1.2 C overload 2 minutes and 2 C overload 15 seconds.
- Automatically managing charging and discharging state and balancing voltage of each cell.
- Supporting CAN/485 two forms of communication; Upgrading battery module through CAN or 485 communication; Support remote upgrade.

## 3.2 Specifications

Specifications	FB-L-5.12/ FB-L-5.12-B
Nominal Voltage (VDC)	51.2
Nominal Capacity (Wh)	5120
Usable Capacity (Wh)	4966
Depth of Discharge (%)	97
Dimensions (mm)	638(W) x 137 (D) x 370(H)
Weight (Kg)	45
Discharge Voltage (VDC)	45.6 ~ 56.8
Charge Voltage (VDC)	56 ~ 56.8
Recommended Charge/Discharge Current (A) *	100
Maximum Continuous Charge/Discharge Current (A) *	100
Peak Charge/Discharge Current (A)	103 ~ 120 @2 minutes 121 ~ 200 @15 seconds
Communication	RS485, CAN
Configuration (maximum quantity in one battery group)	20
Configuration (maximum strings)	6
Working Temperature(°C)**	-10 ~ 55 Charge/-10 ~ 55 Discharge
Storage Temperature (°C)	-20 ~ 60
Short Current/Duration Time (A/1ms)	< 1,000
Cooling Type	Natural
Protective Class	I
IP Rating of Enclosure	IP65
Anti-corrosion	C5-M
Humidity(% , RH, No Condensation)	5 ~ 95
Altitude(m)	≤4000
Certifications	IEC62619, IEC62040、 UN38.3, RoHS, Reach, WEEE, EMC/CE
Design Life (year) (25°C /77°F)	10
Cycle Life (25°C /77°F) **	6000

\*: Support Maximum 100A charge/discharge current, the recommended current will change dynamically according to the real-time status of the battery during operation;

\*\* : In low and high temperature section, BMS will reduce the recommended current and need to be used with reduced power;

\*\*\*: 25°C/0.5C, for details, please seek technical support from PylonTech.

### 3.3 Battery Interface

FB-L-5.12-B

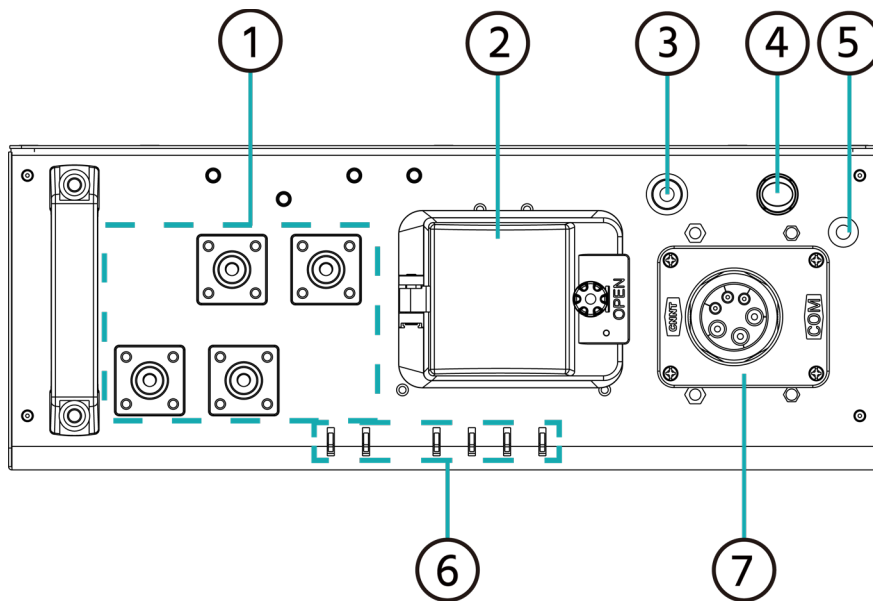

FB-L-5.12

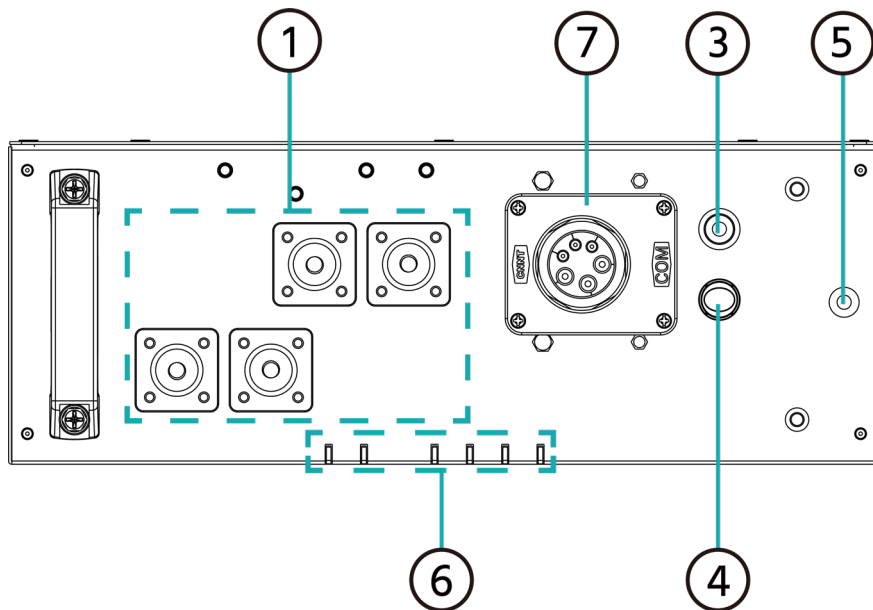

No.	Name	Description
1	Power terminal(s)	<p>There are two pair of terminals with same function, one is connected to equipment, the other is connected in parallel to other battery modules for capacity expansion.</p> <p>For the FB-L-5.12, the cable terminals need to be fixed to the power terminals on the battery with the M8*18 screw (tightening torque: 12 Nm).</p> <p>After the cable terminal is fixed to the battery, a silicone cap should be used to cover on the cable terminal.</p>

No.	Name	Description
2	DC breaker	<p>Only applies to the FB-L-5.12-B model.(FB-L-5.12 does not has circuit breaker.)</p> <p>Used for the disconnection protection of the battery side power circuit, suitable for applications in some regions where the battery side must be equipped with a circuit breaker according to the local regulations.</p> <p>Please close the circuit breaker before turning on the battery.</p>
3	Power button	<ul style="list-style-type: none"> <li>● Switch on: Press the button to lock the status;</li> <li>● Switch off: Press the button again, and it will bounce back to its initial state.</li> </ul> <p><b>NOTE:</b> Please keep the battery powered off during storage or transportation.</p>
4	Start button	<ul style="list-style-type: none"> <li>● Turn on: If the battery is in the “Switch on” state, press more than 0.5 seconds to start the battery.</li> <li>● Turn off: If the battery is in the “Turn on” state, press and hold for more than 5s and release the button to turn off the battery.</li> <li>● Functional reuse: If the battery is in the “Turn on” state, press and hold for 2~5 seconds and then release the button, and the battery 485 communication baud rate switch, the 9600 bps switched to 115200 bps. The battery defaults to 9600 bps, and it will reset every time the battery is turned off.</li> </ul> <p><b>NOTE:</b> For the operation of “Turn off” or “Functional reuse” (baud rate switching), please pay attention to the duration of the long pressing button.</p>
5	Grounding point	To connect the grounding cable.
6	LED status indicators	It is important to check the detailed alarm/protection definitions according to the following table for trouble-shooting and maintenance service. For details, see the table below.
7	Communication Terminals	Before connecting the communication terminals, loosen the 4 screws on the cover as follows, then you will see the communication terminals.

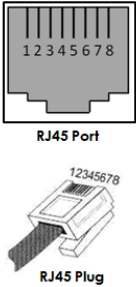
No.	Name	Description																							
		<ul style="list-style-type: none"> <li>RS485: 9600 or 115200 bps. Recommended 60 Ω. To inverter or slave battery.</li> <li>CAN: 500 Kbps. Recommended 60 Ω. To inverter or upper battery.</li> </ul> <table border="1"> <thead> <tr> <th>PIN</th> <th>RS485</th> <th>CAN</th> </tr> </thead> <tbody> <tr> <td>Pin1</td> <td colspan="2" rowspan="3"></td> </tr> <tr> <td>Pin2</td> </tr> <tr> <td>Pin3</td> </tr> <tr> <td>Pin4</td> <td>-</td> <td>CAN-H</td> </tr> <tr> <td>Pin5</td> <td>-</td> <td>CAN-L</td> </tr> <tr> <td>Pin6</td> <td>CAN-GND</td> <td>CAN-GND</td> </tr> <tr> <td>Pin7</td> <td>485A</td> <td>-</td> </tr> <tr> <td>Pin8</td> <td>485B</td> <td>-</td> </tr> </tbody> </table>  <ul style="list-style-type: none"> <li>Link port 0/Link port 1: For communication between multiple parallel batteries.</li> </ul>	PIN	RS485	CAN	Pin1			Pin2	Pin3	Pin4	-	CAN-H	Pin5	-	CAN-L	Pin6	CAN-GND	CAN-GND	Pin7	485A	-	Pin8	485B	-
PIN	RS485	CAN																							
Pin1																									
Pin2																									
Pin3																									
Pin4	-	CAN-H																							
Pin5	-	CAN-L																							
Pin6	CAN-GND	CAN-GND																							
Pin7	485A	-																							
Pin8	485B	-																							

### LED Status Indicators

Condition	Protect	AL M	100~76%	75 ~ 51%	50 ~ 26%	25 ~ 0%	Description
Switch off	-	-	-	-	-	-	All LED lights turn off.
Turn on	●	●	●	●	●	●	When the battery is switched off, all lights turn off. Press and hold the button for ≥ 0.5 seconds, all LED lights will flash once, and the battery will turn on
Soft start	-	-	●	●	●	●	The pre charging circuit is working
Turn off	●	●	●	●	●	●	In the "Turn on" state, long press the button for 5 seconds, then all the lights are solid on; Release the button and switch off, then all the lights are off.
Baud rate Switching	●	●	●	●	●	●	In the "Turn on" state, long press the button for 2 seconds, all the lights on, after releasing the button, all the lights flashes twice, and the baud rate switches from

Condition	Protect	AL M	100~76%	75 ~ 51%	50 ~ 26%	25 ~ 0%	Description
							9600 to 115200.
Idle	-	-					Only current SOC status LED slowly flashes.
Charge							Only current SOC status LED solid.
Float charge							Highest SOC status LED is solid on, and other LEDs flash.
Discharge							100-76% SOC
	-				75-51% SOC		
	-	-			50-26% SOC		
	-	-	-		25-0% SOC		
Alarm	-		Charge status				Charge overcurrent alarm
	-		Discharge status				Discharge overcurrent alarm
			Idle status				Temperature alarm
	-		-	-	-		SOC≤3%, Low battery alarm
Protection		-		-	-	-	Charge protection
		-	-		-	-	Discharge protection.
		-			-	-	Charge and discharge protection
		-	Idle/charge/discharge/float charge status				Internal communication error, Address assignment error.
			-	-	-	-	<b>Critical failure:</b> MOSFAIL; FUSE broken.
: flash 1.5s off/0.5s on				/  /  : flash 1s off/1s on			/  /  : constant lighting

## Communication Terminals

Before connecting the communication terminals, loosen the 4 screws on the cover as follows, then you will see the communication terminals.

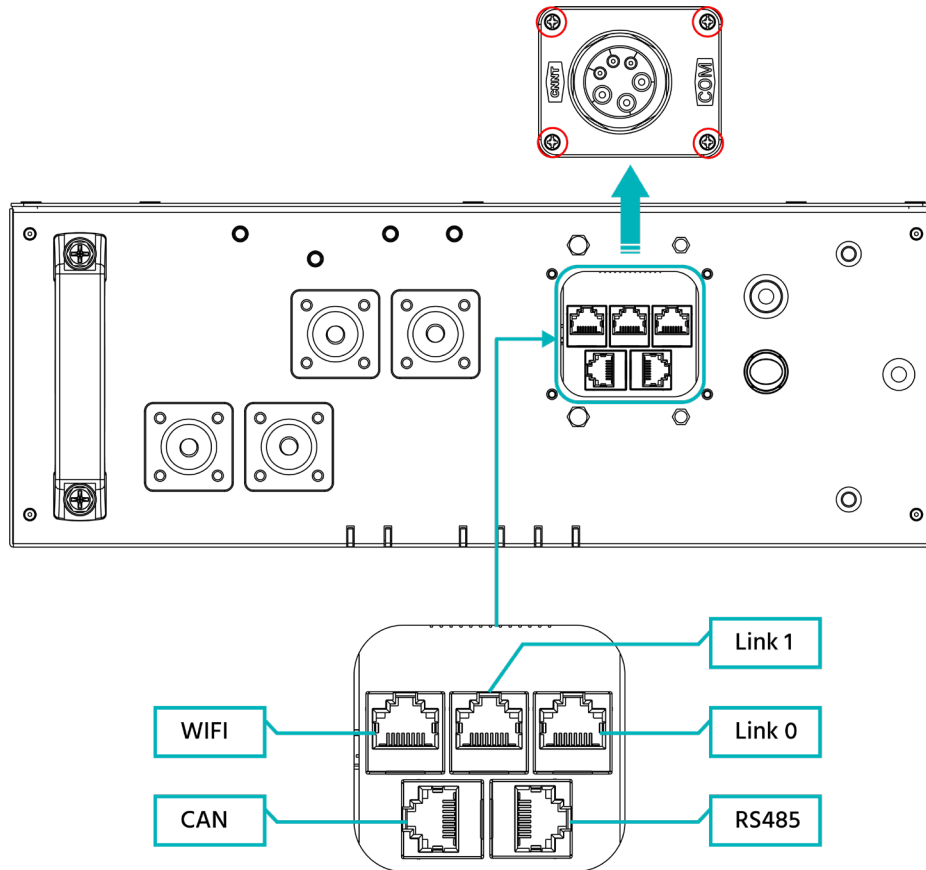

# 4 Safe Handling of Lithium Batteries

## 4.1 Schematic diagram of solution

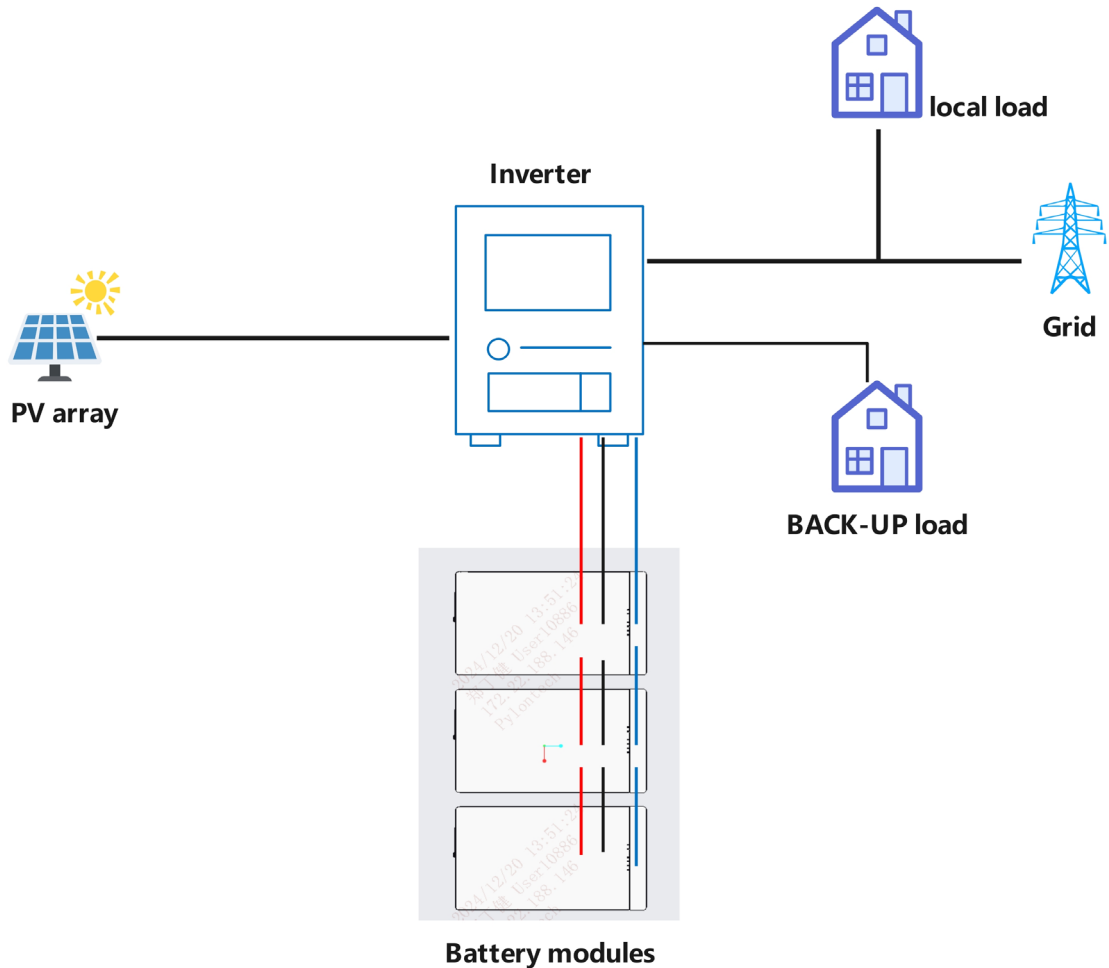

## 4.2 Labels

DANGER
DANGER LOW DC VOLTAGE INSIDE  
DANGER ARC FLASH & SHOCK HAZARD

- \* Do not disconnect or disassemble by non-professional personnel.
- \* Do not drop, deform, impact, cut or spear with a sharp object.
- \* Do not place at a children or pet touchable area.
- \* Do not place near open flame or flammable material.
- \* Do not cover or wrap the product case.
- \* Do not sit or put heavy things on battery.
- \* Do not touch the leaking liquid.
- \* Avoid of direct sunlight.
- \* Avoid of moisture or liquid.
- \* Ensure that the grounding connection is correct before operation.
- \* In the event of leakage, fire, moisture or damage, switch off the breaker on DC side and stay away from battery.
- \* Contact your supplier within 24 hours if any failure happens.

## 5 Installation

### CAUTION

**Caution:** According to local electric safety and installation policy, a suitable disconnection device between battery system and inverter could be installed.

All the installation and operation must follow local electric standards.







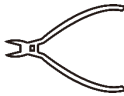
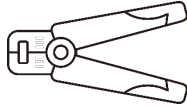

### 5.1 Checking Before the Installation

#### Checking the Outer Packing and Deliverables

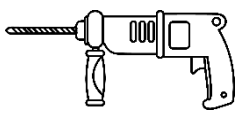
- After receiving the product, check the outer packing for damage, such as holes, cracks, deformation and so on. If any damage is found, contact the local retailer as soon as possible.
- After unpacking the product, check that the deliverables are complete. If any item is missing or damaged, contact the local retailer as soon as possible.

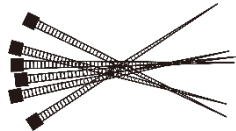
### 5.2 Preparing Tools and Instruments

#### Tools and Instruments

Type	Tools and Instruments		
Installation			
	Wire Cutter	Crimping Plier	Screwdriver
			
	Hammer Drill	Socket Wrench Set	Cable Ties
Personal protective equipment (PPE)			
	Insulated Gloves	Safety Goggles	Safety Shoes
			
Anti-arc Flash Suit			

**NOTE:** Use properly insulated tools to prevent accidental electric shock or short circuits. If insulated tools are not available, cover the entire exposed metal surfaces with available insulated alternatives, except their tips, with electrical tape.

## 5.3 Selecting the Installation Sites

### Working Environment Requirements

#### CAUTION

**Caution:**

If the ambient temperature is out of the operating range, the battery stops working to protect itself. The optimal temperature range for the battery module operation is 15 °C to 40 °C.

Frequent exposures to harsh temperatures may deteriorate the performance and life of the battery.

Ensure that the installation location meets the following conditions:

- Ensure that the battery is not soaked in water.
- The floor is flat. Or if the wall is strong enough to support the battery wall mounting
- There are no flammable or explosive materials.
- The ambient temperature is within the range from 0 °C to 50 °C.
- There is minimal dust and dirt in the area.
- The distance from heat source is more than 2 meters.
- The distance from air outlet of inverter is more than 0.5 meters.
- The installation areas should be protected from direct sunlight.
- There are no mandatory ventilation requirements for the battery module, but please avoid of installation in confined area.
- Do not place heavy objects on top of the battery after installation, and it is recommended to set up isolation in the battery installation area to avoid dropping the battery and hitting people or animals.

## 5.4 Installation Direction

NOT allowed:

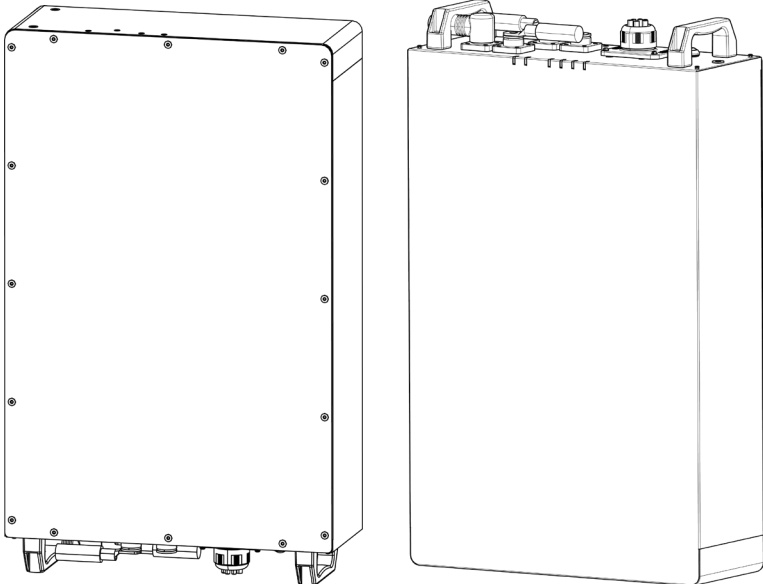
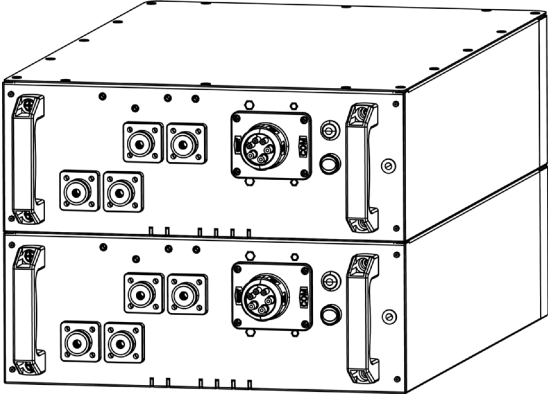
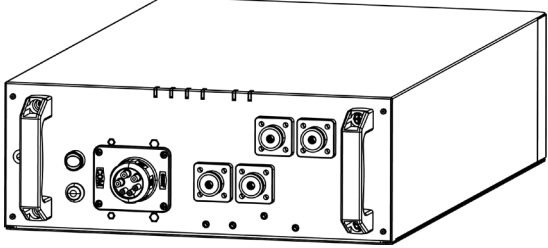
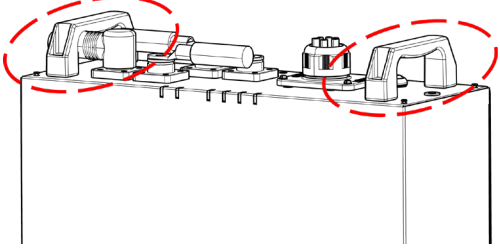
<p><input checked="" type="checkbox"/></p> <p>Do <b>NOT</b> put the module in the upright position.</p>	
<p><input checked="" type="checkbox"/></p> <p><i>Caution:</i> DO <b>NOT</b> stack modules together directly.</p>	
<p><input checked="" type="checkbox"/></p> <p>Do not place the cover plate facing downwards.</p>	
<p><input checked="" type="checkbox"/></p> <p>Do <b>NOT</b> hang the module by the handles.</p>	

**Recommended:**

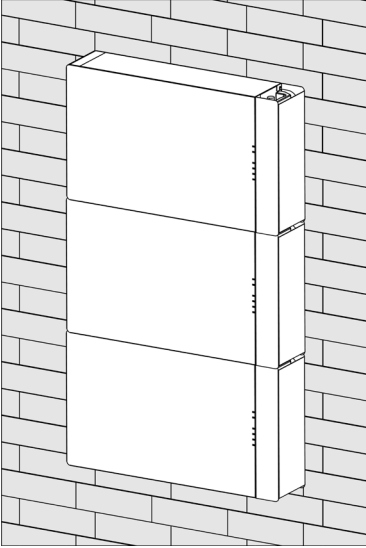
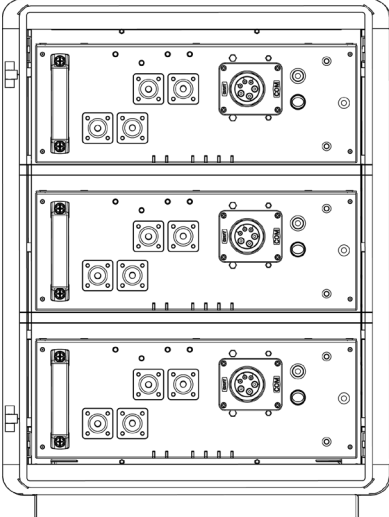
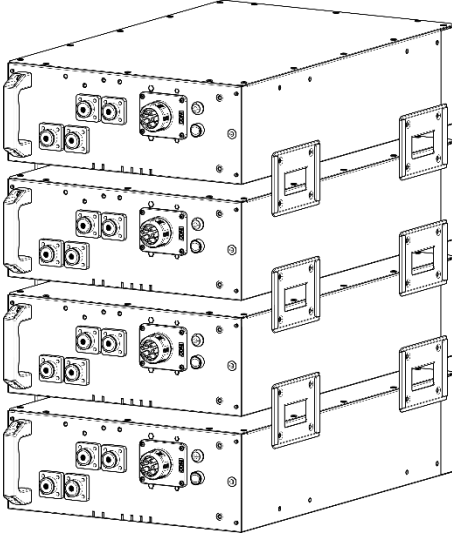
<p><input checked="" type="checkbox"/></p> <p>Mounted on the wall.</p>	 A line drawing showing a rectangular device with a vertical slot on its right side, mounted on a brick wall. The device is oriented vertically and is shown in a three-quarter perspective view.
<p><input checked="" type="checkbox"/></p> <p>Installed into the cabinet or the rack.</p>	 A line drawing of a rack containing three identical devices stacked vertically. Each device has a front panel with various ports and a handle on the left side. The rack has a front door that is slightly open.
<p><input checked="" type="checkbox"/></p> <p>Stacked by simple brackets</p>	 A line drawing showing four identical devices stacked vertically. Each device is connected to the one below it by a simple metal bracket that spans across the front and back of the devices. The devices have a front panel with ports and a handle on the left side.

## 5.5 Installing the Batteries

There are 3 installation methods for battery modules as follows.

### 5.5.1 Mounting the Battery on the Wall

#### Procedure

1. Put the wall bracket on the wall horizontally and mark positions for drilling holes.

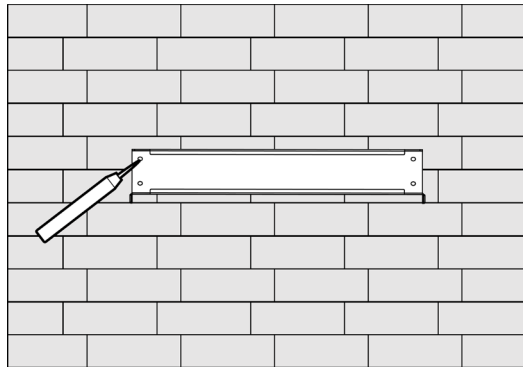

2. Drill holes to a depth of 60 mm using the hammer drill.

The diameter of the drill bit should be 6 mm.

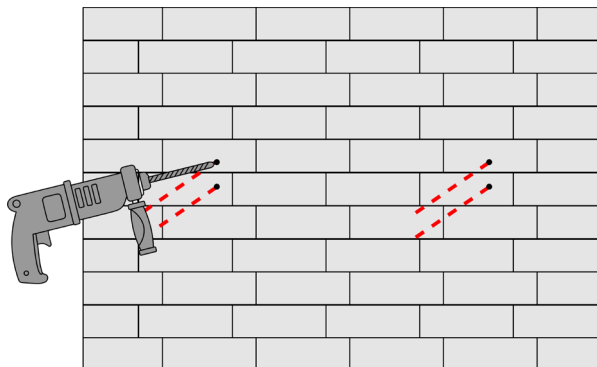

3. Secure the wall bracket using the M6\*60 expansion bolts (tightening torque: 7 Nm).

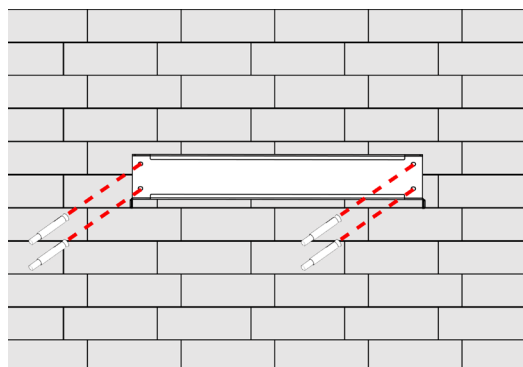

- Use 6 M5 screws to install the 2 mount fixings to the both sides of the battery with M5 screws (tightening torque: 5 Nm).

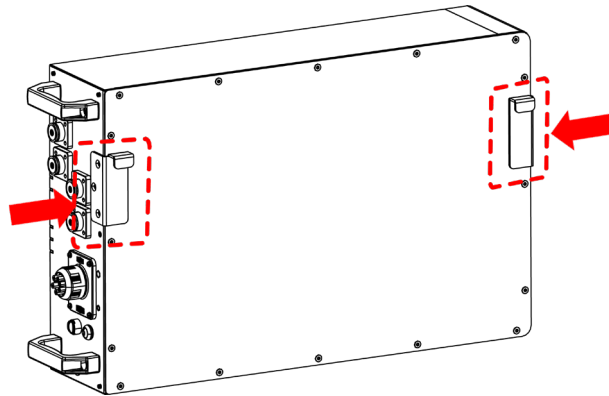

- Remove one handle of the battery and install the handle on the other side of the battery.
- Lift the 2 handles on the battery and adjust to keep the mount fixings of the battery align with the wall brackets.

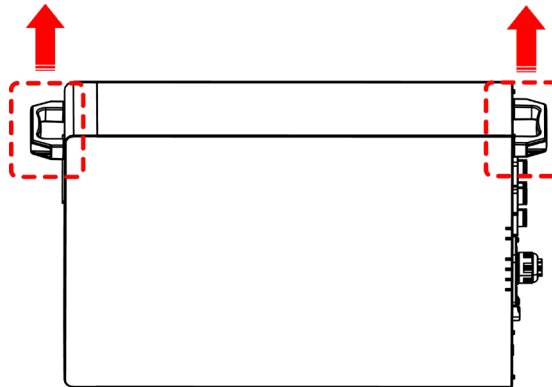

- Slowly put down the battery to fit it properly on the wall bracket and fasten the mount fixings to the wall bracket with 2 M5 screws (tightening torque: 5 Nm).

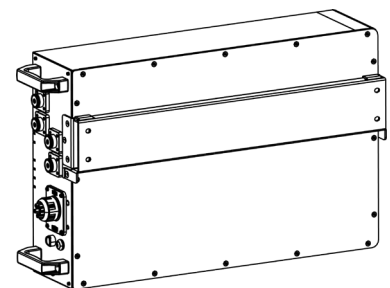
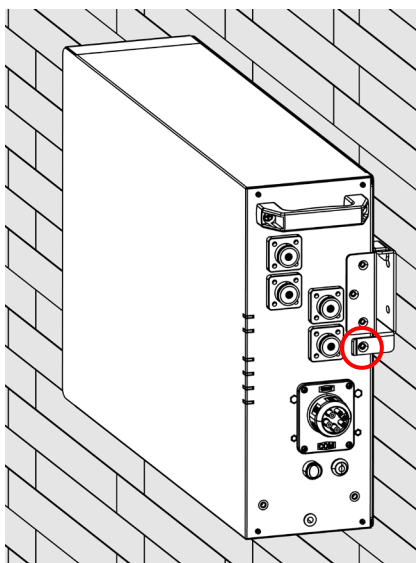

- (If any) Repeat the step 1 to step 7 above if more than one battery needs to be installed.
- Remove the handles on both sides to facilitate the cable connection between the batteries.

10. Connect the cables. (>>>Chapter 6 Cable Connection)
11. Install the decorative cover onto the battery.

**NOTE:** If more than one battery needs to be mounted, ensure that the distance between the upper wall bracket and lower wall bracket is greater than the height(370 mm) of one battery.

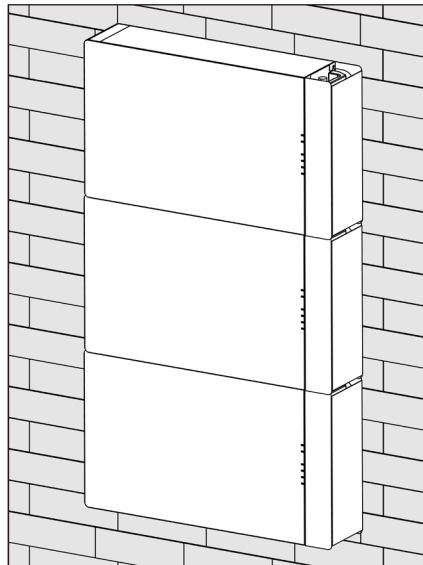

### 5.5.2 Installing the Battery into the Cabinet or Rack

The battery is not designed according to the standard 19 inch cabinet size, so the the rack needs to be based on the battery size by the user.

#### Procedure

1. Put the battery into the cabinet or the rack.

**NOTE:** Ensure that the cover plate is facing upwards.

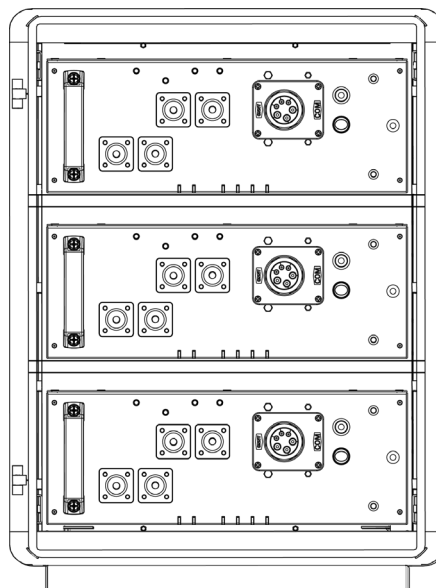

### 5.5.3 Installing the Batteries by Simple Brackets

Up to 4 batteries can be installed by this method.

#### Procedure

1. Install two simple brackets on the left and right sides of the battery cover plate respectively.

**NOTE:** Ensure that the battery cover plate is facing upwards.

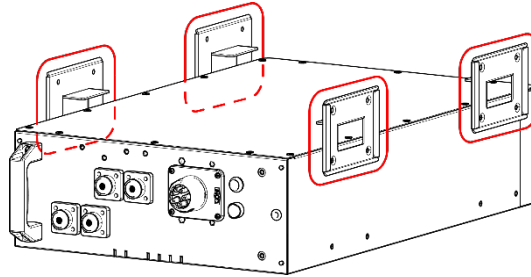

2. Slowly put down another battery onto the 4 simple brackets to fit it properly.
3. Fasten the battery to the brackets with M5\*10 screws (tightening torque: 10 Nm).

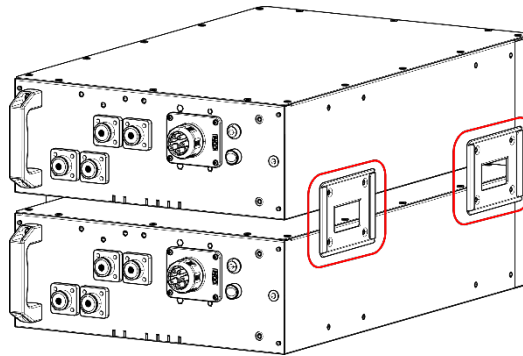

4. Repeat step 1 ~ step 3 above if more than 2 batteries need to be installed.
5. **NOTE:** Maximum 4 batteries are allowed for stacking in one vertical row due to the load-carrying capability of the simple brackets.

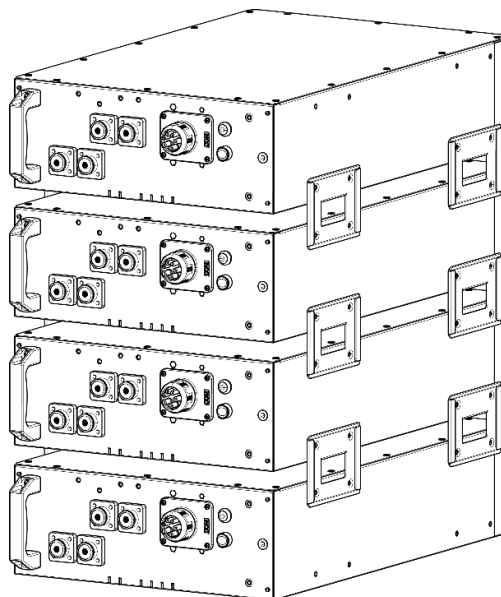

## 6 Cable Connection

### 6.1 Checking Cables

AWG	Maximum Current	Recommended Current
1/0 AWG	250 A	200 A
4 AWG	125 A	100 A

For the FB-L-5.12 battery, either 1/0 AWG cable or 4AWG cable can be used depending on the application.

### 6.2 Connecting the Grounding Cable

Grounding cables should be 6 AWG or higher yellow-green cables. After connection, the resistance from battery grounding point to Ground connection point of room or installed place should be less than 0.1  $\Omega$ .

#### Procedure

1. Connect a grounding cable to the grounding point of the modules.

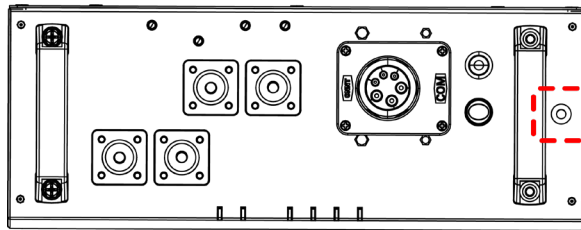

2. Multiple modules also need to be connected using grounding cables.

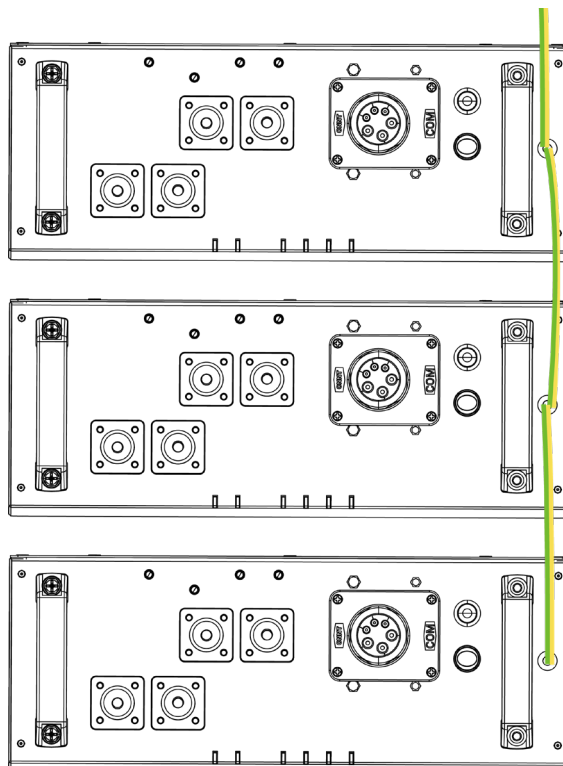

### 6.3 Single-string Cable Connection

#### Procedure

1. Connect the power cables and communication cables between serial battery modules as shown below.
2. Connect the power cable and communication cable to the inverter.

**NOTE:** After the cable terminal is fixed to the battery, a silicone cap should be used to cover on the cable terminal.

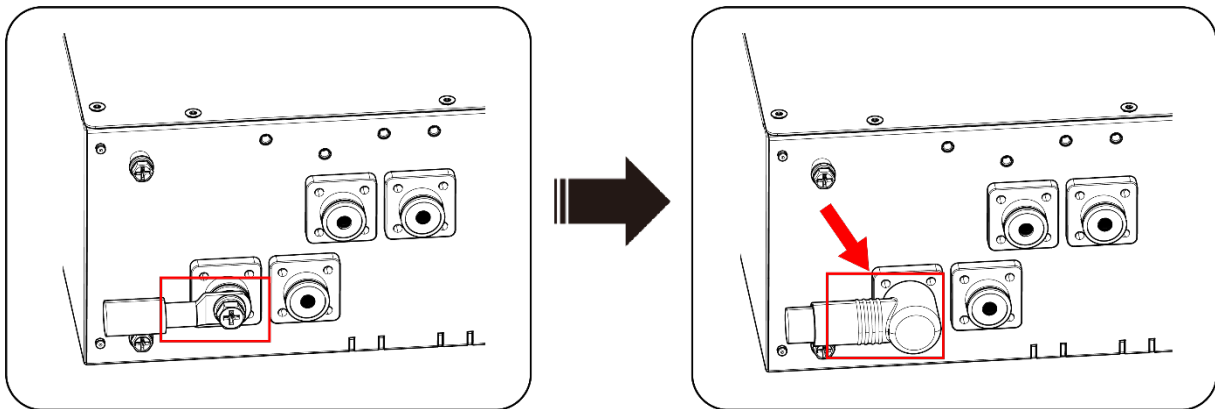

#### Power cable connection

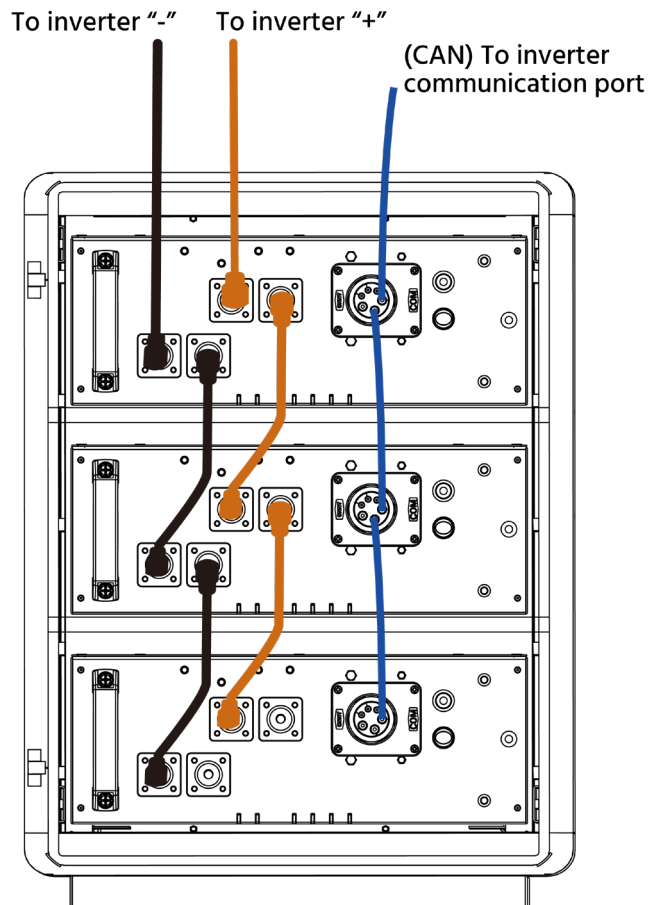

## Communication cable connection

The communication for master/slave battery connection shall use an 8 pin RJ45 cable, connecting from the first battery Link 1 to the second battery Link 0, then from the second battery Link 1 to third battery link 0(if has), all the way to the last battery Link 0.

The battery with Link 0 EMPTY is defined as the Master battery. Select either CAN or RS485 on the master battery for further connection with the inverter or upper controller.

The CAN/RS485 Port of the slave battery is ineffective in this case.

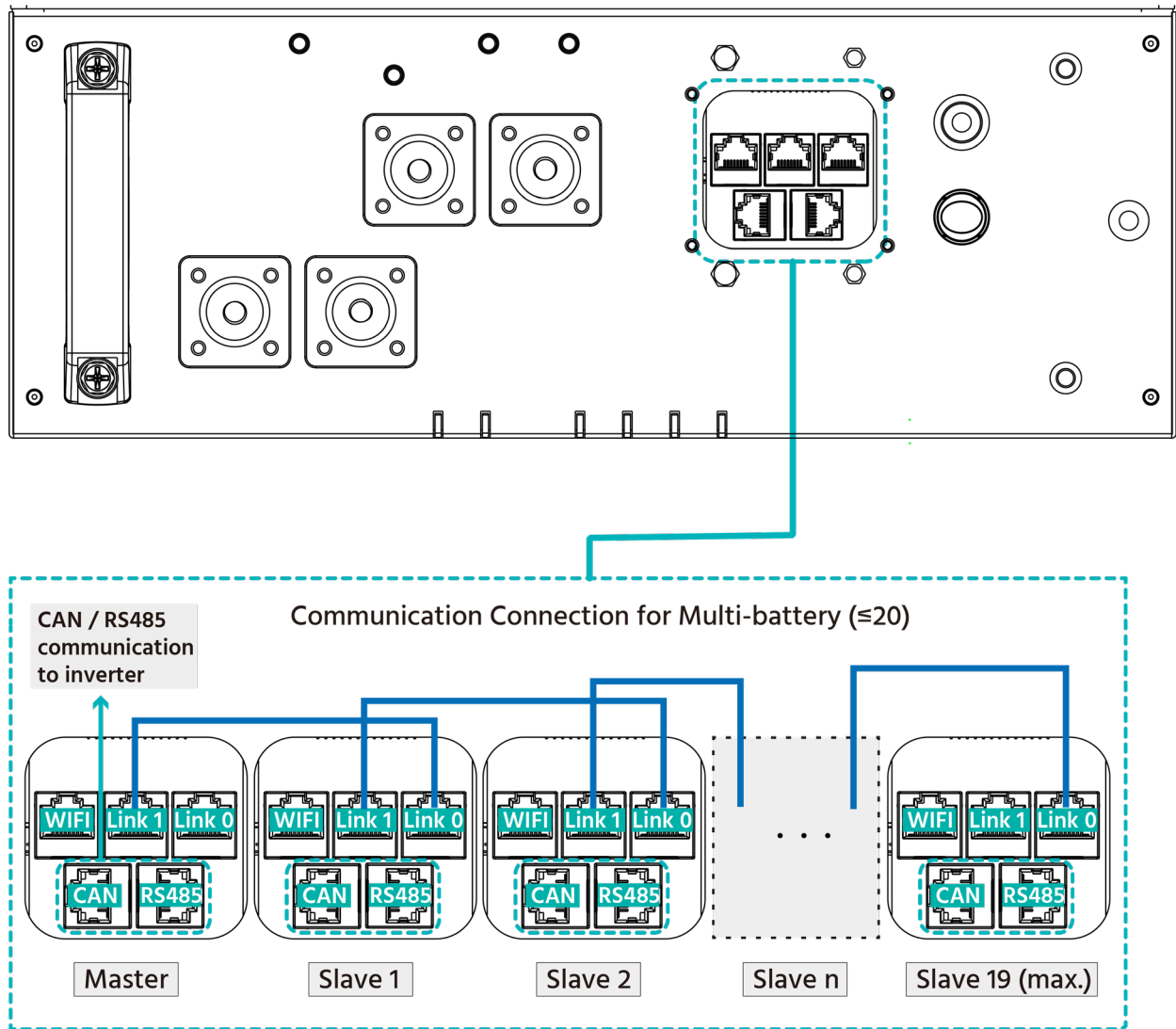

## 6.4 Multi-string Cable Connection

### Power cable connection

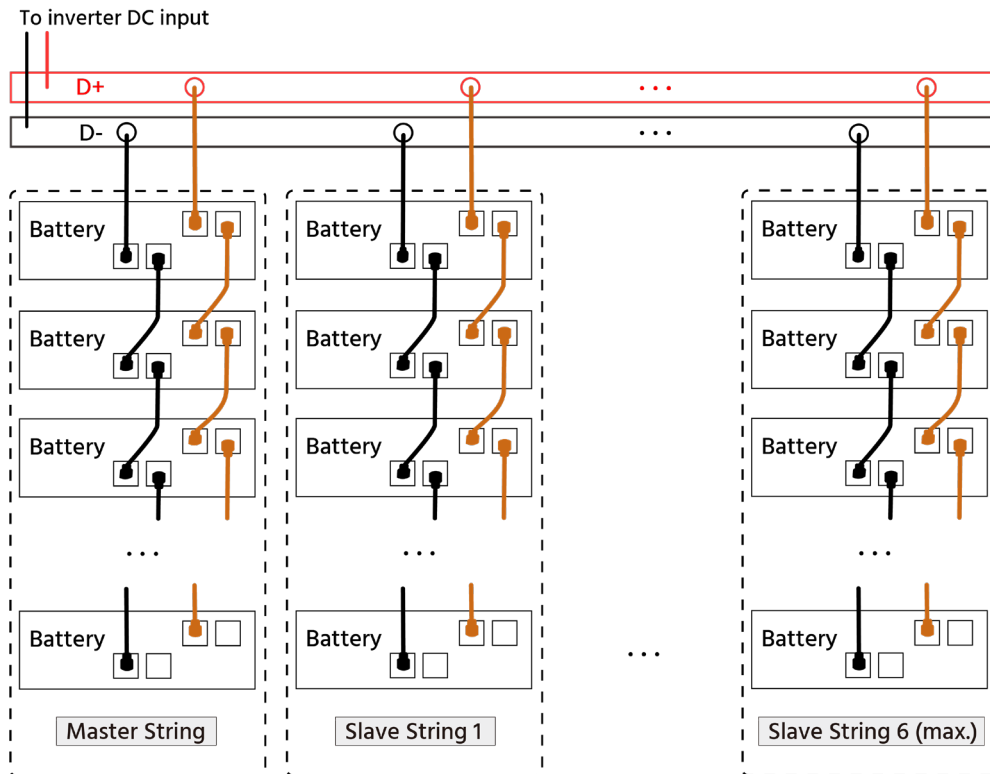

### Communication cable connection

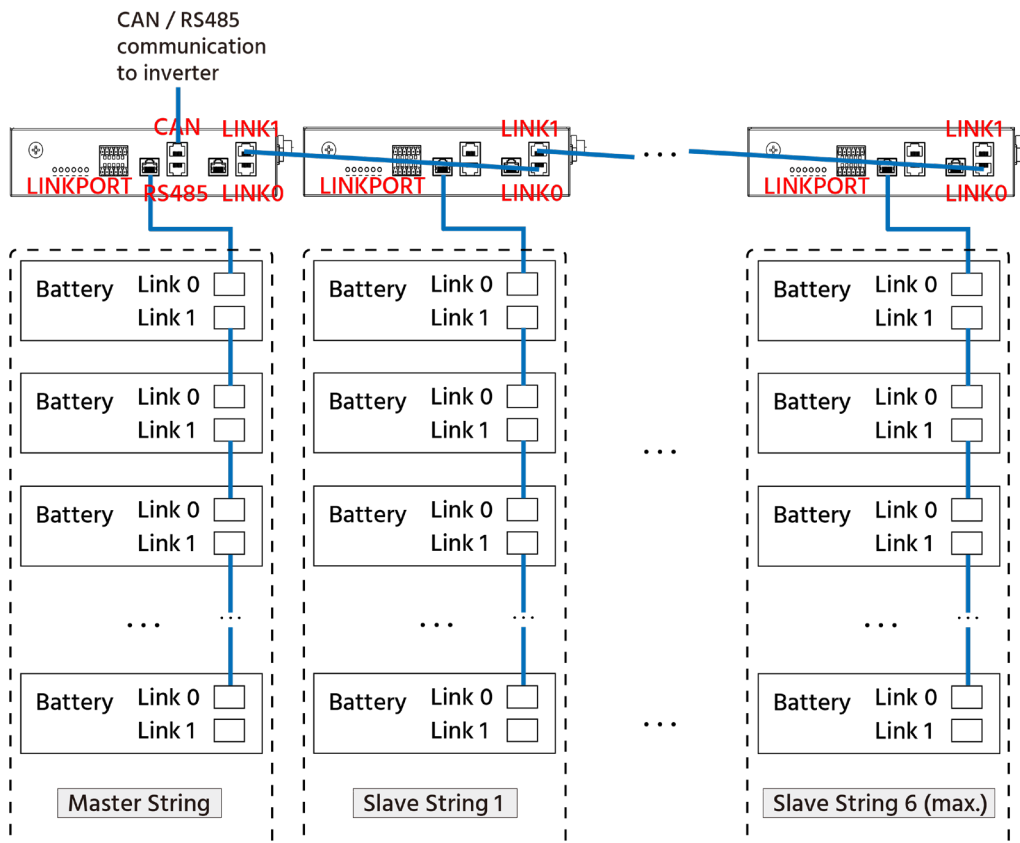

**NOTE:** After installation, DO NOT forget to register online for full warranty:

[www.pylontech.com.cn/service/support](http://www.pylontech.com.cn/service/support)

## 6.5 Suitable disconnection device

It is recommended to have a disconnection device for protection between battery system and inverter:

1) The rated voltage should be  $\geq 60\text{VDC}$ . **DO NOT** use an AC breaker.

2) The rated current should match with system design:

The following factors shall be considered:

- The maximum DC current on inverter side.
- The number of power cable: for instance, if there is only one pair of 4 AWG cable, the rated current of breaker shall be  $\leq 125\text{ A}$ . If there is only one pair of 1/0 AWG cable, the rated current of breaker shall be  $\leq 250\text{ A}$ .

3) If using a breaker, it shall be type C (recommended) or type D.

The Icu required: the maximum short circuit current for calculation of each module is 1000 A.

For instance:

Battery amount	Icu of breaker
1~4 modules	Must $\geq 4\text{ kA}$
5~8 modules	Must $\geq 8\text{ kA}$

## 7 Commissioning

### 7.1 System Turning On

Double check all the power cables and communication cables between batteries and between battery and inverter. Switch ON the disconnection device between battery and inverter if available.

#### Procedure

1. Power on all the battery modules.

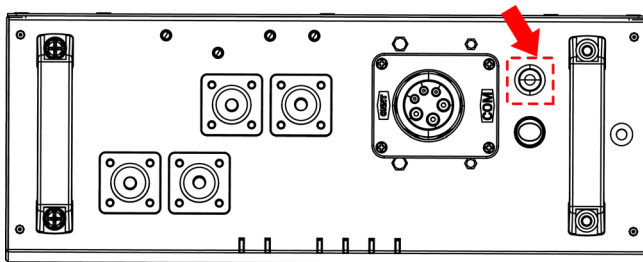

The one with **empty Link Port 0** is the **master battery**, others are slaves (1 master battery configuring maximum 19 slave batteries).

2. Press the **red start button** of **master battery** to turn on. After the master battery LED turns on, the LEDs on all the slave batteries will be on at the same time.

#### **NOTE:**

- After the battery module is powered on, the pre-charging circuit will continue to work for 3 seconds. Once the precharge is complete, the battery is ready for high power output.
- When connecting modules with different SOC/voltage in parallel during expansion or replacement, it is recommended to maintain the system in IDLE for  $\geq 15$  minutes or till the SOC LEDs become similar ( $\leq 1$  dot difference) before normal operation.

### 7.2 System Turning Off

#### Procedure

1. Turn external power source off.
2. Press the Start button of the master battery for 5 seconds, then release it, and all batteries will be turned off.
3. Turn Power Button to OFF on master battery and all slave batteries.
4. Switch off the disconnection device between battery system and inverter, if available.

## 8 Trouble shooting

- **Communication related problems**

A. Unable to communicate with inverter on compatible list.

**Possible conditions:**

a) RS485: baud rate.

Please confirm if the 485 communication baud rate set by the master battery is correct, refer to the instructions of Start button and LED Status Indicators in *section 3.3 Battery Interface*.

b) Pin definitions.

Check whether the CAN or 485 communication connection and PIN definition of the battery are correctly connected to the corresponding PIN definition of the inverter.

- **Function related problems**

A. Whether the battery can be turned on or not

B. If the battery is turned on, check that the red light is off, flashing or lighting

C. If the red light is off, check that the battery can be charged/discharged.

**Possible conditions:**

a) Battery cannot be turned on or power ON. And the lights are all not lighting or flashing when pressing the red SW.

1) Capacity too low, or module over discharged.

**Solution:** use a charger or inverter to provide 51.2~56.8 V voltage.

If the battery can be turned on, then keep charging the module and use monitor tools to check the battery log.

Depending on the different battery terminal voltages, take the following 2 methods:

- If the battery terminal voltage is  $\leq 45$  VDC, use  $\leq 0.05$  C to slowly charge the module to avoid affecting SOH;
- If battery terminal voltage is  $> 45$  VDC, use  $\leq 0.5$  C to charge.
- If the battery cannot start, turn off and repair the battery.

b) The battery can be turned on, but red light is on, and the battery cannot charge or discharge.

If the red light is on, it means that system is abnormal. Please check the following values:

1) Temperature: If the temperature is above  $60^{\circ}\text{C}$  or under  $-10^{\circ}\text{C}$ , the battery will not work.

**Solution:** move battery to the normal operating temperature range between  $0^{\circ}\text{C}$  and  $50^{\circ}\text{C}$ .

2) Current: If the current exceeds 100 A, the battery protection will be activated.

**Solution:** Check whether current is too large, and if it is, change the settings on power supply side.

3) High Voltage: If the charging voltage is above 57.6 V, battery protection will be activated.

**Solution:** Check whether voltage is too high. And if it is, change the settings on power supply side. And discharge the module.

4) Low Voltage: When the battery discharges to 45 V or less, battery protection will be activated.

**Solution:** Charge the battery till the red light is turned off.

5) High Cell voltage: The module voltage is lower than 56.8 V, SOC LEDs are not all on. When discharging the module, the protection disappears.

**Solution:** Keep charging the module by 56~56.8 V or keep the system cycle. The BMS can balance the cell during cycling.

c) Unable to charge and discharge with red LED on. The temperature is 0~50°C. Use charger to charge, not possible. Use load to discharge, not possible.

1) Under permanent protection. The single cell voltage is higher than 4.2 V or lower than 1.5 V; Or single cell temperature is higher than 80°C.

**Solution:** Power off the module and contact your local distributor to repair.

d) Unable to charge and discharge without red LED off. The temperature is 0~50°C. It is impossible to use charger to charge and load to discharge.

1) Fuse broken.

**Solution:** power off the module and contact your local distributor for repair.

e) Buzzer rings and Protect LED red.

1) Over voltage protection.

Cell voltage higher than 3.9 V or module voltage higher than 59.5 V.

**Solution:** Battery system requires properly established communication with inverter and correct settings on inverter to run safely. Check that the setting of the inverter or charger, the charge voltage should be 56~56.8 VDC; Check whether the communication between battery system and inverter is established;

Under this condition, the BMS remains functional without damage. Just leave the module switched OFF and wait for the battery voltage to drop down naturally (15 minutes) and then restart. If then no alarm comes out, this means the module is ready for work.

2) Reverse connection of cables.

**Solution:** Power off all batteries and inverters. Disconnect breaker. Check the cable connection and disconnect all power cables. Check that the power port is damaged. Then try to turn on the single module without any cable connected. If there is no alarm, then it is reverse connection of cables. Switch off the module and contact your local distributor.

3) MOSFAIL.

**Solution:** Power off all batteries and inverters. Disconnect breaker. Check the cable connection and disconnect all power cables. Check that the power port damaged. Check the setting of inverter or charger. Check the communication between inverter and battery system. Power off the module and contact your local distributor.

f) After power on, the module turns on directly.

1) BMS failure.

**Solution:** power off the module and contact your local distributor.

Refer to instructions of Status Indicators in *section 3.3*, which may also help you locate and identify some problems.

**Excluding the points above, if the faulty still cannot be located, turn off battery and contact your local distributor.**

## 9 Emergency Situations

### CAUTION

**Caution:** Damaged batteries may leak electrolyte or produce flammable gas.

Problem	Description	Action	
Leaking Batteries	If the battery pack leaks electrolyte, avoid contacting with the leaking liquid or gas. If anyone is exposed to the leaked substance, immediately perform the actions.	Inhalation.	Evacuate the contaminated area and seek medical attention.
		Contact with eyes.	Rinse eyes with flowing water for 15 minutes and seek medical attention as soon as possible.
		Contact with skin.	Wash the affected area thoroughly with soap and water, and seek medical attention as soon as possible.
		Ingestion.	Induce vomiting and seek medical attention.
Fire	The battery cell is catching fire.	<ol style="list-style-type: none"> <li>1. Firstly, cut off the external power supply.</li> <li>2. Then use vast of water for suppression.</li> <li>3. After extinguishing the fire, soak the battery in water and contact Pylontech or an authorized dealer.</li> </ol>	
	The cabling or other component (not battery cell) is catching fire.	<ol style="list-style-type: none"> <li>1. Firstly, cut off the external power source.</li> <li>2. Then use dry powder fire or carbon dioxide extinguisher for suppression.</li> </ol>	
Wet Batteries	The battery module is wet or submerged in water.	<ol style="list-style-type: none"> <li>1. Cut off all power switch on inverter side.</li> <li>2. DO NOT let people access it, and contact Pylontech or an authorized dealer for technical support.</li> </ol>	
Damaged Batteries	Damaged batteries are dangerous and must be handled with the utmost care. They are not fit for use and may pose a danger to people or property.	If the battery pack seems to be damaged, pack it in its original container, and then return it to Pylontech or an authorized dealer.	

## 10 Remarks

### 10.1 Recycle and disposal.

If a battery (normal condition or damaged) needs disposal or needs recycling, follow the local recycling regulation (i.e. Regulation (EC) N° 1013/2006 among European Union) to process, and use the best available techniques to achieve a relevant recycling efficiency.



### 10.2 Storage, Maintenance and Expansion

- 1) It is required to charge the battery at least once every 6 months, ensure that the SOC is charged to higher than 90% for this charge maintenance.
- 2) It is suggested to check the connection of power connector, grounding point, power cables and screws every year after installation. Make sure that there is no loose, no broken, no corrosion at connection points. Check the installation environment such as dust, water, insect etc. Make sure that it is suitable for IP65 battery system.
- 3) A new battery module can be added onto an existing system at any time. Make sure that the new battery is acting as the master. The new module, due to a higher SOH may have a difference on SOC with existing system, but it will not affect the parallel connection system performance.







**Pylon Technologies Co., Ltd.**

No.300, Miaoqiao Road, Kangqiao Town

Pudong New Area, Shanghai 201315, China

**T** +86-21-51317699

**E** [service@pylontech.com.cn](mailto:service@pylontech.com.cn)

**W** [www.pylontech.com.cn](http://www.pylontech.com.cn)