

**Narada**®

ŠQ P Q V T Á Ü U P Á Ü P U Ü Ü P Q V Ò Á Ó C E V Ò Ü Y

---

# NESR Series

Š Q P Q V T Á Ü U P Á Ü P U Ü Ü P Q V Ò Á Ó C E V Ò Ü Y

Í F È P Ò Ü Ü 1 € €

## OPERATION MANUAL

X ^ ! • q } Á È Ò

---

P Ò Ü Ü C Ó Á Ü Y Ò Ü Á Ü W Ü Ò Ò Á Ó Ü È Š Ö

Ò { š q P Q V T Á Ü U P Á Ü P U Ü Ü P Q V Ò Á Ó C E V Ò Ü Y } È š q P Q V T Á Ü U P Á Ü P U Ü Ü P Q V Ò Á Ó C E V Ò Ü Y {

<b>Notes   Safety and Warning</b>	<b>03</b>
<b>One   Product Introduction</b>	<b>04</b>
Øæ   ^•	I
Schematic diagram of solution	I
Öä ^} •ä }	Í
Šæ [ ~ c	î
Y [ \ ä * Á i ä &ä   ^	ì
<b>Two   Technical Characteristic</b>	<b>10</b>
Öä & @ * ^ Á ^ i t i { æ & ^	€
Ô @ * ^ Á ^ i t i { æ & ^	€
<b>Three   Operation</b>	<b>11</b>
Úææ ^ ¢ i Á ^ ¢ä * • Á	FF
U ] ^ i æä } Á [ } á ää }	FF
<b>Four   Storage and Installation</b>	<b>12</b>
Ùç i æ ^ Á	FG
Q • ¢ä ää }	FG
<b>Five   Maintenance</b>	<b>18</b>
Ö ^ } ^ i æ	F8
V i [ ~ à   ^ • @ [ ç * Á ä á Á [   ~ ç } •	19
Ç } ^ ¢ F—Insrtuctions for LED Flash	21
Ç } ^ ¢ G—Insrtuctions for ADD DIP Switch	G2
Ç } ^ ¢ H—Communication protocol for CAN and RS485	G4



## Dimension

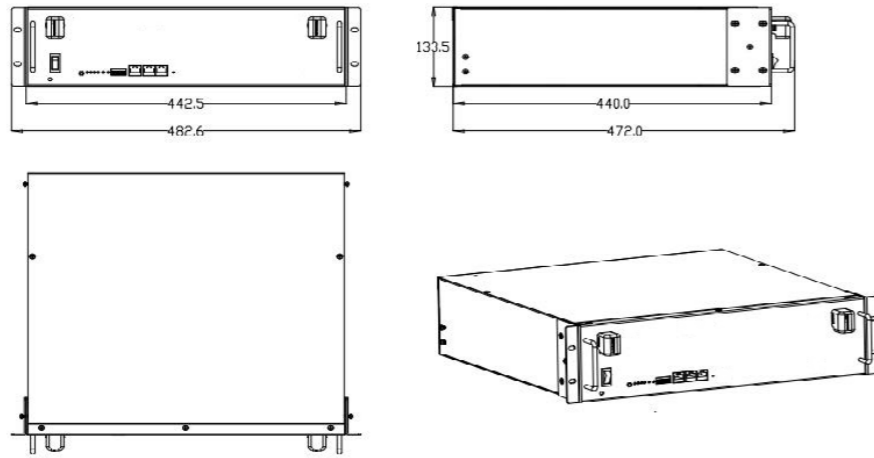

Fig.1-1 Structural Drawing of NESR Series Batteries



Fig.1-2 Battery Output Terminal

Table 1-1 Battery Model & Dimension of NESR Series

Battery Model <sup>①</sup>	Typical Weight (kg)	Dimensions(mm)			Battery Output Terminal Φ
		Width (No ear)	Height	Depth	
51.2NESR100	42.0	442.5	133.5	440	M8

Note:

1. Battery Model: Battery models listed in the datasheet are standard products. Narada can also supply customized design in cell, BMS and dimensions for various application scenarios.

2. Terminal Torque: M4, 2~3 N·m; M6, 7~8 N·m; M8, 9~10 N·m;

## Layout



Fig. 1-3 Layout of Front Panel for 51.2NESR100 Series Batteries

(Received product may not have all parts above, this instruction is as an example)

Table 1-2 Instruction for Layout of Front Panel

No.	Marks	Functions	Detailed Information
1	Hanging ears	Cabinet Installation	Hanging ears are used to fix batteries in cabinets.
2	GND	Ground screw	Connect earth by flexible cable above GREEN Sheathed, UL94-V0, gauge of the grounding wire should be equal to or greater than the gauge of the battery return wire.
3	Power Switch	ON/OFF Switch	When turn-off, battery get into sleep mode, and cut-off output, the alarm output also will be stopped.
4	SOC	Indicators for capacity	SOC is short for state of charge. There are four green LED lights in front panel indicating SOC. Each SOC LED light represents 25% of rated capacity. Detailed information is shown in Annexed Table 1.1.

5	Alm	Indicators for alarms	There is one red LED light in front panel indicating alarms. Detailed information is shown in Annexed Table1.3
6	RUN	Indicators for running status	There is one green LED light in front panel indicating running status. Detailed information is shown in Annexed Table1.2
7	ADD DIP Switch	Address of communication	ADD is applicable to modules connected in parallel. ADD consists of eight binary bits. Detailed information is shown in Annex 2.
8	CAN	Communication Interface	The baud rate is 500K. It can be used for host battery and inverter connection.
9	RS485	Communication port	1) Contents of data transmit include BMS parameters,battery running status,alarms,etc. 2) Communications of modules connected in parallel is available through RS485.
10	Reset	Reset Button	Press RESET button when abnormality occurs to assure stability of battery performance.
11	Battery output	Terminals for battery output	+,-from left to right.Detailed information is shown in Fig1-2.
12	Handle	Handle	The handle is used to push and pull the battery easily from battery cabinet.

## Working Principle

The NESR battery system mainly includes Lithium battery pack, battery protection, cell balancing unit, monitoring module and charge-discharge management module for optional. Its schematic diagram shown in Figure 1-4

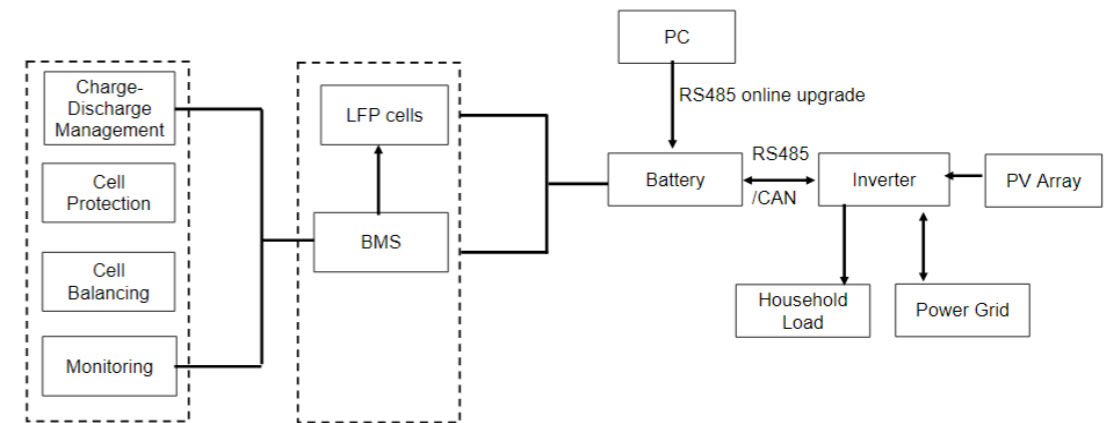

Fig. 1-4 Schematic Diagram

LFP cells	Chemical power, energy storage and power supply components.
Cell protection	Protect LFP cells against overcharge, over discharge, over current, over temperature, short circuit
Cell balancing	Equalization LFP cells for cells unbalanced
Monitoring	Support centralized monitoring system (optional according to customer requirements)

### NESR battery working principle:

When the power grid is powered off, it can be powered by the battery, and the DC power is converted into AC power through the inverter, and finally transmitted to the load or the power grid. The electricity from the PV array or grid is passed through the inverter to convert the alternating current into direct current and store it in the battery.

### Battery Management System (BMS)

Smart BMS technology is adopted for battery modules of NESR series to assure smart automatic management for batteries. Features of BMS are shown as below:

- There is a centralized monitoring unit in BMS. Functions such as remote measurement, remote communication, remote controlling are available. Battery modules can be controlled remotely by staffs in control center.
- The communication with the inverter can be CAN or RS485. And BMS supports RS485 online upgrade function.
- Excellent electromagnetic compatibility. BMS used for battery modules of NESR series can comply with the outdoor power plants during operation, no interfere with each other.
- BMS can provide protections against overcharge, over-discharge, over-temperature, over current, short circuit, etc., to assure reliable safety and operation life.
- With patented cell balancing technology, BMS provide high efficiency for cell balancing and prolong system operate life.
- Configuration flexibility, support parallel connection expansion. The NESR battery supports up to 16 groups of parallel expansion, and BMS adopts master-slave control logic. When multiple batteries are connected in parallel, select one as the host and the others as the slaves. The definition of master and slave can be set through ADD address, and the setting method refer to **Annex 2**.

# Technical Characteristic

## Chapter Two/02

### Discharge performance

CC Discharge to 43.2V at different constant current rate

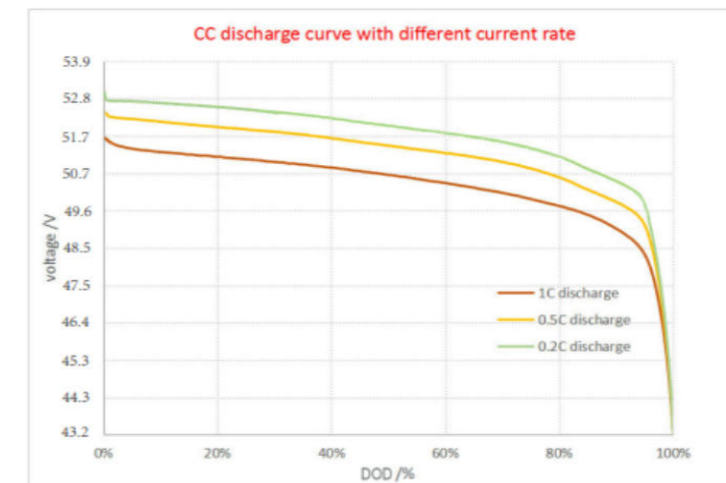
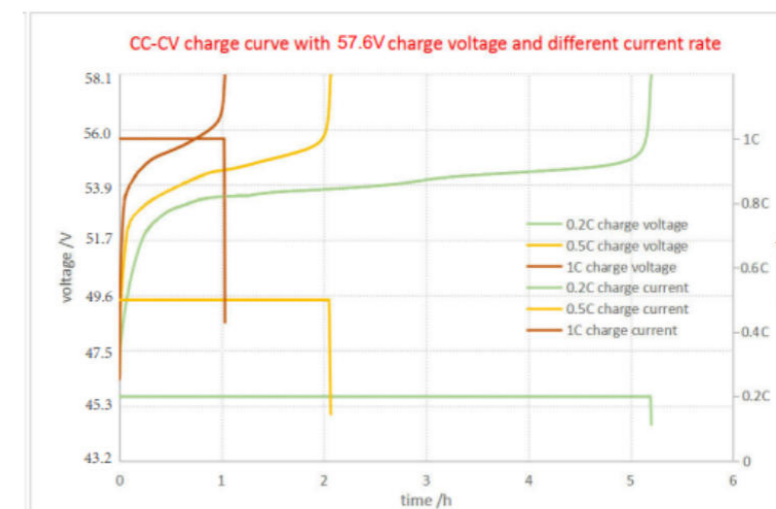

Fig.2-1 Discharge curve at different constant current of NESR series

### Charge performance

CC-CV charge with different constant current rate and 57.6V constant voltage



Note: The maximum charge and discharge current of NESR100 battery is 100A

# Operation

## Chapter Three/03

### Parameter settings

Lead-acid batteries can be replaced by lithium battery of NESR series if power is matched. Table 3-1 is new parameter settings of power plant for lithium battery.

**Table 3-1 Parameter Settings of Power Plant for NESR Series Batteries**

No.	Parameters	Units	Defaults
1	Float charge voltage	V	56
2	Equalization charge voltage	V	57.6
3	Standard charge current	A	0.2C
4	Charge current limitation	A	0.5C ~ 1.0C
5	Equalization charge interval	day	NA
6	Equalization charge duration	H	NA
7	Condition to equalization charge	A	NA
8	Condition to float charge	A	0.05C
9	Recovered LLVD voltage	V	53.4
10	LLVD	V	50.0
11	BLVD	V	46.4
12	Temperature compensation for float charge	-mV/°C	NA
13	Temperature compensation for equalization charge	-mV/°C	NA

Note:

1. Rectifier parameter shall be set according to specific site requirement based on battery units used.
2. If the battery connected more than 2 in parallel, the max. charge current recommend 0.5C.
3. Every 30 days, the battery needs to be equalized charging at least one time.

### Operation Condition

**Table 3-2 Requirements for Operation Environment**

Temperature Range (°C)	Discharge	-20 ~ +60
	Charge	0 ~ +60
	Storage	0 ~ +40
Recommended Temperature(°C)	Discharge	+15 ~ +35
	Charge	+15 ~ +35
	Storage	+15 ~ +30
Humidity		5% ~ 95%

# Storage and Installation

## Chapter Four/04

### Storage

- Storage temperature range: 0°C to 40°C.
- Storage battery should be at 50%-80%SOC.
- Recharge charge before using to recover capacity loss of self-discharge during storage and transport.
- Recharge battery during long-term storage for self-discharge. Recharge program as follow table:

Storage temperature	Recharge interval	Single Module Recharge Procedure
0°C-30°C	Every 6 months	1) Charge with 0.2C to 100%SOC 2) Discharge with 0.2C to 0%SOC
30°C-40°C	Every 3 months	3) Charge with 0.2C per module for 4 hours

- Storage battery over 40°C or under 0°C will reduce battery life,
- Storage battery in dry and low temperature, well ventilated place
- Battery performance degradation after long-term storage, please shorten shelf time as possible as you can.

### Installation

#### Unboxing & Inspection

- Please study this manual before installation.
- Please inspect the package before unboxing, if any destroy with appearance, contact with the supplier as soon as possible.
- This device shall be installed and operated by professionals.

#### Preparation for Installation

- Batteries shall not be placed in direct sunshine or close to heat source.
- Batteries shall be installed in place with good ventilation to assure enough heat dissipation.
- Batteries shall be placed in are with clean ambient and low humidity.
- Heavy weight shall not be placed on any cable.
- Following are the tools possibly but not limited be use for installation:



Tool items (possibly but not limited)

## Installation of Battery Modules

### 1.Installation and fixation

Battery modules of NESR series are applicable to installation in cabinets or stacking. Please make sure the battery is turned off before installing, and switch is OFF.

#### ■ Cabinet installation

Insert battery module into cabinet, and fix two handles of battery module with cabinet rack using 4PCS M6 screws.

#### ■ Stacking installation

Stacking installation also can be adopted, Stack two batteries through the bracket and fix them with the locking devices, and stacking up to 6 layers .

Note: The mounting bracket is an optional device, If necessary, please purchase separately.



Preferred

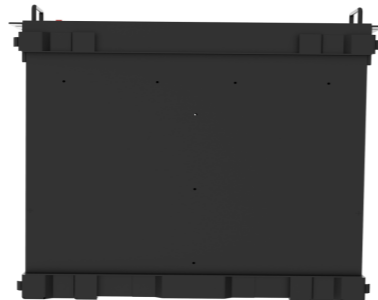

Alternate



Forbidden



### 2.Ground connection

Connect earth by flexible cable above GREEN Sheathed, UL94-V0, gauge of the grounding wire should be equal to or greater than the gauge of the battery return wire, .no less than 6AWG, connection through 2-hole 0.75in center spacing, on right side of cabinet back.



Fig. 4-1 Ground connection for NESR Series Batteries

### 3.Battery output connection

■ Connect the BAT+ interface of the inverter to the "+" of the host battery; connect the BAT+ interface of the inverter to the "-" of the host battery.

■ If multi battery modules will be connected in parallel, please take note of follows:

- 1) The battery modules connected no more than 16 in parallel. The minimum spacing between
- 2) batteries is 10mm.
- 3) To make sure similar voltage drop of cable for each battery, length of all positive and negative cables should be the same.

■ Color for cable between '+' and positive bar is suggested as RED, and cable between '-' and negative as BLACK.

■ The picture of paralleling connection for NESR Series Batteries see Fig. 4-2. There is a tray under each battery to support the battery. The steps to assemble the battery into the cabinet are as follows:

- 1) Put the batteries into the cabinet from bottom to top;
- 2) Connect the power line (parallel): connect the "+" and "+" between the battery and the battery with the red cable; connect the "-" and "-" between the battery and the battery with the black cable.

3) Connecting the communication cable (parallel): Connect the RS485 port of battery 1 and the RS485 port of battery 2 with a parallel network cable, and so on, use network cables to connect all batteries in the cabinet in parallel.

Note: The interface definition of the network cable is in accordance with the requirements of this manual.

4) According to the guidance of this manual, set the dial addresses of the battery master and slave respectively.

5) Connect the power cable of the host battery and the inverter.

6) Establish the communication connection between the host battery and the inverter: connect the RS485 interface of the host battery and the RS485 interface of the inverter, or connect the CAN interface of the host battery and the CAN interface of the inverter (select CAN or RS485 communication according to the actual situation).

#### 4. Installation diagram

##### 1) Cabinet installation

Put the battery modules into cabinet and connect the cables.

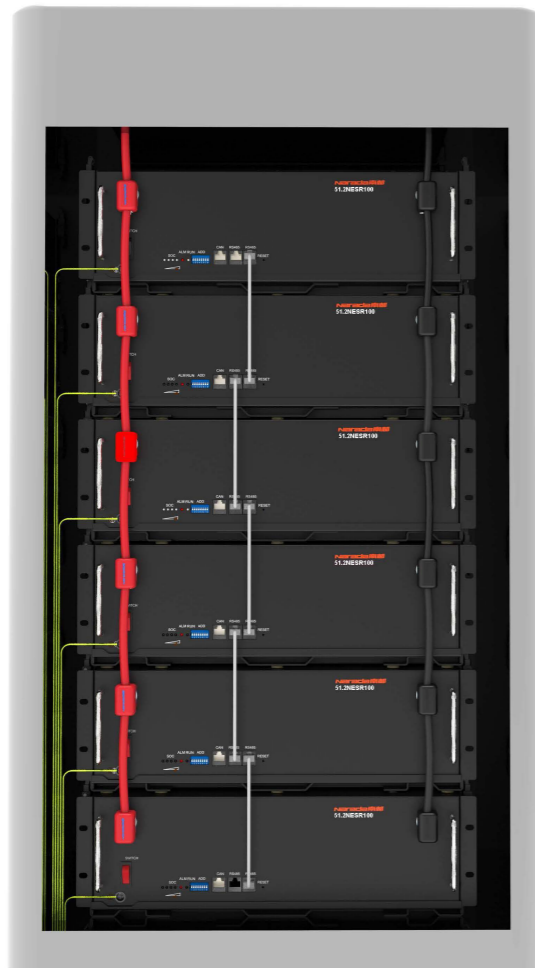

Fig. 4-2 Layout of paralleling connection for NESR Series Batteries

##### 2) Stacking installation

Put the battery into 2 pcs of bracket and use 4 location holes, stack the batteries together.



Fig. 4-3 Schematic diagram of 2 groups of battery stacking



Fig. 4-4 Maximum 6 in stack

## 5. Turn on battery module

- When installation is accomplished, battery module is in dormant state. Once turn on for the power plant and battery module, battery will go into normal running status, and discharge/charge can be available.
- Parameter settings for lithium battery modules in power plant are shown in Table 3-1.

## 6. CAN / RS485 communication connection

- If there is only one battery module in operation, communication between battery module and computer can available through RS485.
- If there are more than one battery modules in operation, parallel communication can be available using RS485.
- The last battery in each rack has an empty RS485 port, its need to be connected with a cable with RJ45 terminals to avoid interference with communication. The other end of the cable should covered with insulating tape.

If the battery and the inverter use RS485 communication, connect the RS485 port of the host battery to the RS485 port of the inverter ;If the battery and the inverter use CAN communication, connect the CAN port of the host battery to the CAN port of the inverter.

- Communication protocols for RS485 and CAN are shown in Annex 3.

## 7. UI Software Instruction

If the NESR battery matches the inverter, you need to use the BMS UI software to set the inverter brand to be matched. See Annex 4 for details.

## 8. Parallel expansion

NESR battery supports up to 16 groups in parallel, and the recommended charging and discharging current refer to the table below.

Parallel Numer	2 ~ 4	5 ~ 6	7 ~ 8	9 ~ 12	13 ~ 16
Charge A	50 X N	40 X N	30 X N	20 X N	15 X N
Discharge A	50 X N	40 X N	30 X N	20 X N	15 X N

# Maintenance

## Chapter Five/05

### General

Proper maintenance will prolong the life of a battery and will aid in assuring that it can satisfy its design requirements. A good battery maintenance program will serve as a valuable aid in determining the need for battery replacement. The users must consider their application and reliability needs if maintenance procedures, other than those recommended in this document, are used. Battery maintenance should be performed by personnel knowledgeable of batteries and the safety precautions involved.

- The battery shall be recharged every three months if in long time storage
- Please clean the dust by the dust collector when dust is accumulated on vent
- Please use clean and dry cloth/fabric to clean up the cabinet, if need further cleaning, please use neutral cleanser. Alcohol or ammonia synthesis is forbidden.
- Carrying shall be handled gently, prevent from severe compact
- Prevent battery from splashing liquid
- Suggest inspect the tighten of output screw every two years

# Troubleshooting and Solutions

## 1. Functional related problem

1) **Battery cannot turn on, switch ON and press the red SW the lights are all no lighting or flashing.**

**Possible reasons:** Capacity too low, or module over discharged.

**solution:** use a DC power or inverter to provide 48-57.6V voltage. If battery can start, then keep charge the module and use monitor tools to check the battery log.

If battery cannot start, turn off battery and repair.

2) **The battery can turn on, but red light is lighting, and cannot charge or discharge.**

**Possible reasons:** If the red light is lighting, that means system is abnormal, please read the fault information of BMS by the UI Software.

**solution:** Turn off all battery and inverters, and then turn on all battery and inverters.

Make sure that the charging and discharging current , temperature of the battery are within the normal operation range.

## 2. Communication related problem

**Unable to communicate with inverter on compatible list.**

1) **Unable to communicate with inverter on compatible list. Please refer to Annex3.**

2) Master and slave batteries setting: Multiple groups connect in parallel , and communicate with inverter, the master and slave battery must be set first , the ADD setting please refer to **Annex2.**

**Unable to communicate with UI Software.**

1) **Unable to communicate with UI Software. Please refer to Annex3.**

2) Make sure the ADD select on the UI Software is same as set on the BMS.

Table 5-1 Troubleshooting and Solutions

Troubles	Troubleshooting	Solutions
Battery cannot discharge	Protection against under-voltage	Charge battery
	Protection against over-temperature or under-temperature (cell temperature is lower than -20°C or higher than 70°C)	Regulate cell temperature in the range of -20°C to 70°C for discharge
	Battery output is short circuit	Relieve short circuit and charge battery
	Protection against over current	Remove some unimportant load and charge battery
	System failure	Shutdown system and call maintenance service
Battery cannot charge	Battery is fully charged. Normal charge management	Do not need to solve
	Protection against over voltage	Do not need to solve
	Protection against over-temperature or under-temperature (cell temperature is lower than -10°C or higher than 70°C)	Regulate cell temperature in the range of 0°C to 55°C for charge
	System failure	Shutdown system and call maintenance service
All LED indicators on	System failure	Shutdown system Call for maintenance service
Communication failure	Fault of communication cable	Inspect communication cable
	Halt of System communication management	Press RESET button
	System failure	Shutdown system Call for maintenance service

Different flash status of LED indicators represents corresponding running status or alarms. Detailed information is shown Annex 1.

Note: The improvement of product and technology, and the possible of battery specification and appearance changes, Narada hold the right of final explanation

## Annex 1-Instructions for LED Flash

**Annex Table 1.1 – SOC LED Indicators Description**

●	●	●	●	SOC
☀	☀	☀	☀	75% ~ 100%
☀	☀	☀	○	50% ~ 75%
☀	☀	○	○	25% ~ 50%
☀	○	○	○	0% ~ 25%

Note: ☀ mean light on, ○ mean light off

**Annex Table 1.2 – RUN Indicators Description**

Flash Status	Running Status of Battery
Flash 1	Activation state, but neither charge nor discharge
Flash 2	Charging state
Continue light	Discharging state
Extinguish	Dormant state

**Annex Table 1.3 – ALM Indicators Description**

Flash Status	Alarm Information of Battery
Extinguish	Minor Alarm(Various Alarm Status)
Flash 2	Fail(Various fail)
Flash 3	Major Alarm(Various protection status)
Extinguish	Normal, no alarm

**Annex Table 1.4 – Flash Instruction of LED Indicators**

Flash Status	ON	OFF
Flash 1	0.25s	3.75s
Flash 2	0.5s	0.5s
Flash 3	0.5s	1.5s

## Annex2 – Instructions for ADD Dip Switch

ADD Dip Switch is applicable to modules connected in parallel.

DIP switch definition: bit1~bit4 is used to set the slave address or parallel number according to the master-slave status, bit5~bit8 is used to set the inverter protocol type and is used as the master at the same time.

Note:

Master setting: bit1~bit4 is used to set the number of parallel connections, Bit5~bit8 is used to set the inverter protocol type.

**Annexed Table 2.1 –Master battery DIP address setting**

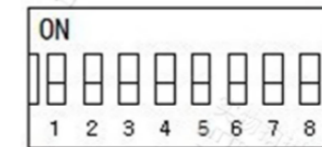

The number of parallel batteries	DIP switch position			
	#1	#2	#3	#4
1	ON	OFF	OFF	OFF
2	OFF	ON	OFF	OFF
3	ON	ON	OFF	OFF
4	OFF	OFF	ON	OFF
5	ON	OFF	ON	OFF
6	OFF	ON	ON	OFF
7	ON	ON	ON	OFF
8	OFF	OFF	OFF	ON
9	ON	OFF	OFF	ON
10	OFF	ON	OFF	ON
11	ON	ON	OFF	ON
12	OFF	OFF	ON	ON
13	ON	OFF	ON	ON
14	OFF	ON	ON	ON
15	ON	ON	ON	ON

Master battery set the number of batteries connected in parallel

Note:

Since RS485 communication is used between the NESR battery and the Voltronic inverter, the DIP address of the BMS needs to be set to the slave DIP address.

The communication protocol serial number	DIP switch position				Brand of the inverter
	#5	#6	#7	#8	
1	ON	OFF	OFF	OFF	Solis
2	OFF	ON	OFF	OFF	Deye
3	ON	ON	OFF	OFF	Growatt
4	OFF	OFF	ON	OFF	Luxpower
5	ON	OFF	ON	OFF	SMA
6	OFF	ON	ON	OFF	Studer
7	ON	ON	ON	OFF	Megarevo
8	OFF	OFF	OFF	ON	Must
9	ON	OFF	OFF	ON	Victron
10	OFF	ON	OFF	ON	Zenergy
11	ON	ON	OFF	ON	Reserved
12	OFF	OFF	ON	ON	Reserved
13	ON	OFF	ON	ON	Reserved
14	OFF	ON	ON	ON	Reserved
15	ON	ON	ON	ON	Reserved

Master battery set inverter protocol

Note:

Slave settings: bit1~bit4 is used for slave address setting, set according to the device order, slave address range 1 to 14, bit5~bit8 fixed to OFF.

**Annexed Table 2.2 – Slave battery DIP address setting**

DIP address	DIP switch position							
	#1	#2	#3	#4	#5	#6	#7	#8
1	ON	OFF	OFF	OFF	OFF	OFF	OFF	OFF
2	OFF	ON	OFF	OFF	OFF	OFF	OFF	OFF
3	ON	ON	OFF	OFF	OFF	OFF	OFF	OFF
4	OFF	OFF	ON	OFF	OFF	OFF	OFF	OFF
5	ON	OFF	ON	OFF	OFF	OFF	OFF	OFF
6	OFF	ON	ON	OFF	OFF	OFF	OFF	OFF
7	ON	ON	ON	OFF	OFF	OFF	OFF	OFF
8	OFF	OFF	OFF	ON	OFF	OFF	OFF	OFF
9	ON	OFF	OFF	ON	OFF	OFF	OFF	OFF
10	OFF	ON	OFF	ON	OFF	OFF	OFF	OFF
11	ON	ON	OFF	ON	OFF	OFF	OFF	OFF
12	OFF	OFF	ON	ON	OFF	OFF	OFF	OFF
13	ON	OFF	ON	ON	OFF	OFF	OFF	OFF
14	OFF	ON	ON	ON	OFF	OFF	OFF	OFF

## Annex 3 – Communication Protocol for CAN and RS485

There are 2 RS485 and 1 CAN interface on the front panel, and one RS485 port in front panel for communication between battery and PC, also for communication between battery modules connected in parallel.

**Annex Table 3.1 – RJ45 Pins Assignment (CAN)**

RJ11 Pins	Definitio	Sketch
4	CAN-H	
5	CAN-L	
1,3,8	No connection	
2,6,7	No connection	

**Annex Table 3.2 – RJ45 Pins Assignment (RS485)**

RJ45 Pins	Definitio	Sketch
2,7	RS485_1A	
1,3,8	RS485_1B	
4	RS485_2A	
6	RS485_2B	
5	NC	

## After-sale Services

### **NARADA POWER SOURCE CO., LTD.**

Building A, No.822 Wen'er West Road, Hangzhou, Zhejiang, China

Tel: +86-571-56975980

Fax: +86-571-56975955

Website: [en.naradapower.com](http://en.naradapower.com) E-mail: [intl@narada.biz](mailto:intl@narada.biz)

### **NARADA ASIA PACIFIC PTE. LTD.**

Block 9 Khaki Bukit Road 1 #02-10 Eunos Technolink, Singapore 415938

Tel: +65-6848 1191

Fax: +65-6749 3498

Website: [www.narada-ap.com](http://www.narada-ap.com)

Email: [sales@narada-ap.com](mailto:sales@narada-ap.com)

### **NARADA EUROPE (UK) LIMITED**

Spectrum House, Dunstable Road, Redbourn, St. Albans, Herts AL3 7PR

Tel: +44 (0)845 612 2031

Fax: +44 (0)845 612 2031

E-mail: [sales@naradaeurope.com](mailto:sales@naradaeurope.com)